



Precision Workholding Technology

*Technical Documentation
for CB-NX, CB-ND, & CB-NS
Collet Chucks*

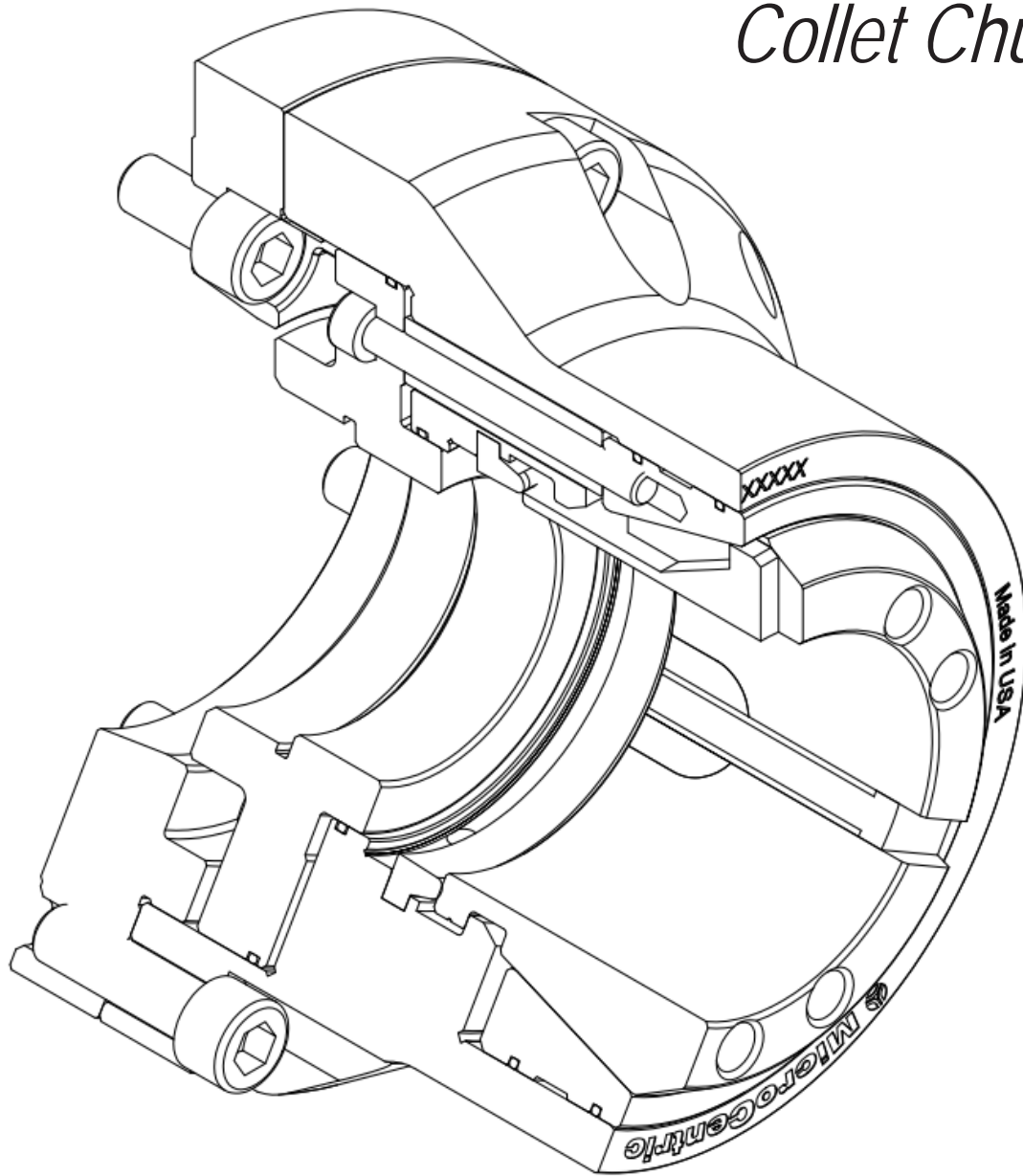

TABLE OF CONTENTS

1.0 Contact & Service Information	2
2.0 Introduction	3
3.0 Precautions for Safe Operation	4
4.0 Recommended Tightening Torque for Mounting Screws	8
5.0 Collet Models, Specifications & Capacities.....	9
5.1 Quick Change Collets	9
5.2 “S” Pad Master Collets.....	9
6.0 Collet Chuck Models & Specifications	10
6.1 CB-NX Collet Chucks	10
6.2 CB-ND Collet Chucks	10
6.3 CB-NS Collet Chucks	10
7.0 Chucking Guidelines.....	11
7.1 Accuracy and Runout	11
7.2 Clamping Force	12
7.3 Clamping Short Workpieces	12
7.4 End Stopping a Workpiece	13
7.5 Centrifugal Force	13
8.0 Collet Chuck System Assembly.....	14
9.0 Collet Chuck Installation	15
9.1 Mounting Adapter Plate	15
9.2 Mounting Chuck Assembly	16
10.0 Quick Change and “S” Pad Master Collets.....	17
10.1 Collet Installation	17
10.2 Collet Removal	17
11.0 Changing Fixture Assembly and Parts List	18
11.1 Manual Collet Changing	18
11.2 Piston Grip Collet Changing	18
11.3 Pneumatic Collet Changing	19
12.0 Assembly Drawing and Parts List.....	20
12.1 CB-NX Collet Chuck Assembly and Parts List.....	20
12.2 CB-ND Collet Chuck Assembly and Parts List	21
12.3 CB-NS Collet Chuck Assembly and Parts List.....	22
13.0 Trouble Shooting Guide.....	23
14.0 Spindle Data Sheet.....	24

1.0 CONTACT AND SERVICE INFORMATION

Manufactured by:
MicroCentric Corp.
Plainview, NY USA
www.microcentric.com

Service in North America:
MicroCentric Corp.
25 South Terminal Drive
Plainview, NY 11803 USA
Phone: 1-516-349-7220
E-mail: sales@microcentric.com







Service in Europe:
MicroCentric GmbH
Ringstrasse 134
70839 Gerlingen
Germany
Phone: 49-71156-17819-00
E-mail: info@microcentric.de

Service in Asia:
Dynamic Tools Corp.
7-4-6 Seikadai, Seika-cho
Sorakugun
Kyoto 6190238 Japan
Phone: 81-774-98-0518
E-mail: dynex@earth.email.ne.jp

2.0 INTRODUCTION

MicroCentric Collet Chucks offer unmatched accuracy and long term performance. The information contained in this manual, if properly followed, will enable you to take full advantage of your chuck's capabilities.

We recommend you read through this entire manual to familiarize yourself with the installation and operation of MicroCentric collet chucks before installing and using your chuck. We also suggest you keep this manual at hand for future reference. This manual is also available for download at microcentric.com.

	<h3>SAFETY ALERT SYMBOL</h3> <p>This symbol is used to call attention to items that could be dangerous to you or persons using this equipment. Please read these messages and follow these instructions and safety regulations before use.</p>
	<h3> DANGER</h3> <p>Indicates an imminent hazardous condition which, if not avoided, could result in serious injury or death.</p>
	<h3> WARNING</h3> <p>Indicates a potentially hazardous condition which, if not avoided, could result in serious injury or death.</p>
	<h3> CAUTION</h3> <p>Indicates a potentially hazardous condition which, if not avoided, could result in injury.</p>
	<h3>IMPORTANT</h3> <p>Instructions for optimum performance and avoiding errors or misuse of chuck.</p>

3.0 PRECAUTIONS FOR SAFE OPERATION



DANGER



Switch off power to the machine before installing or changing the chuck.

- The machine spindle may inadvertently be switched on, and the turret indexed or jogged, potentially causing serious injury to the operator.



DANGER



Do not operate the control valve (foot pedal) or solenoid valve during spindle rotation.

- The workpiece will be thrown from the chuck, potentially causing serious injury to the operator.



DANGER



Do not exceed maximum recommended speed of the chuck for a given input pressure.

- The workpiece can be thrown from the chuck due to inadequate gripping force as a result of centrifugal force.



DANGER



Never wear gloves, loose clothing, or ties while operating a machine tool. Secure long hair.

- Gloves, loose clothing, ties, and long hair can become caught in the chuck causing serious injury to the operator as the spindle is rotated.



DANGER



Always lift the chuck by using an eyebolt or lifting belt, and stand clear of suspended loads.

- The operator can be injured and the chuck can be damaged if the chuck is dropped.



WARNING



Do not start the machine with the door open.

- The operator could be injured by cutting chips or other flying debris.



WARNING



Remove eyebolts after use.

- Rotating the chuck without removing eye bolts may cause them to be thrown from the chuck, potentially causing serious injury.



WARNING



Make certain the mounting bolts are securely tightened to the recommended torque values.

- The chuck could become loose during operation causing damage to the chuck and potentially throwing the workpiece from the chuck.



WARNING



Never attempt to operate a machine tool while under the influence of drugs or alcohol.

- Damage to the machine, tooling, and chuck, or serious injury to the operator could result.



WARNING



Do not attempt to modify the chuck.

- The workpiece can be thrown from the chuck due to damage which may be caused to the chuck.



WARNING



Long workpieces should be supported by a live center in the tail stock or by a steady rest.

- The workpiece can be thrown from the chuck if it is too long and not properly supported.



CAUTION



Do not touch machined workpieces with bare hands.

- Machined workpieces may be very hot, and may cause burns.

 **CAUTION**

Remove workpiece when stopping the machine for an extended period of time.

Clamping force may be lost unexpectedly, causing the workpiece to drop.

 **CAUTION**

Never hit the outside of the chuck, collet, or workpiece with a hammer.

- The workpiece can be thrown from the chuck if the chuck is damaged.

 **CAUTION**

Ensure workplace is clean.

- Danger of slipping and falling from a dirty floor, such as lubricants or oil.

 **CAUTION**

Always make sure to keep your hands and fingers clear of the top jaws and workpiece as the chuck is clamped.

- The operator can be seriously injured if a finger or hand is clamped between the top jaw and the workpiece.

4.0 RECOMMENDED TIGHTENING TORQUE FOR MOUNTING SCREWS

SOCKET HEAD CAP SCREW SIZE (CLASS 12.9)	M5	M6	M8	M10	M12	M14	M16	M20
TIGHTENING TORQUE [N*m]	7.5	13	33	73	107	171	250	402
TIGHTENING TORQUE [lb*ft]	5.5	9.6	24	54	79	126	184	297

5.0 COLLET MODELS, SPECIFICATIONS & CAPACITIES

5.1 QUICK CHANGE COLLETS

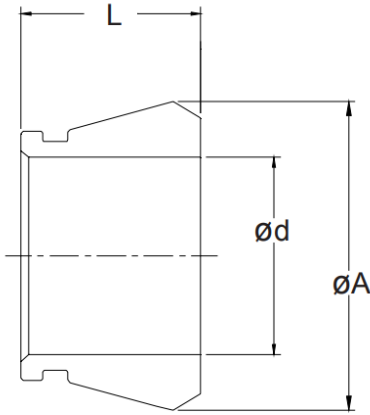

Collet Model	Ød Max.	ØA	L	Range
SK42BZI	1.625"	3.122"	1.850"	± 0.020"
	42mm	79.3mm	47mm	± 0.5mm
SK52BZI	2.047"	3.122"	1.811"	± 0.020"
	52mm	79.3mm	46mm	± 0.5mm
SK65BZI	2.625"	3.917"	2.284"	± 0.020"
	66mm	99.5mm	58mm	± 0.5mm
SK80BZI	3.250"	4.500"	1.945"	± 0.020"
	82.5mm	114.3mm	49.4mm	± 0.5mm
SK100BZI	3.937"	5.589"	2.323"	± 0.040"
	100mm	144.5mm	59mm	± 1.0mm
SK120BZI	4.724"	7.087"	2.402"	± 0.040"
	120mm	180mm	61mm	± 1.0mm
SK140BZI	5.590"	7.667"	2.480"	± 0.040"
	142mm	194.7mm	63mm	± 1.0mm
SK160BZI	6.299"	8.858"	2.480"	± 0.040"
	160mm	225mm	63mm	± 1.0mm

5.2 "S" PAD MASTER COLLETS

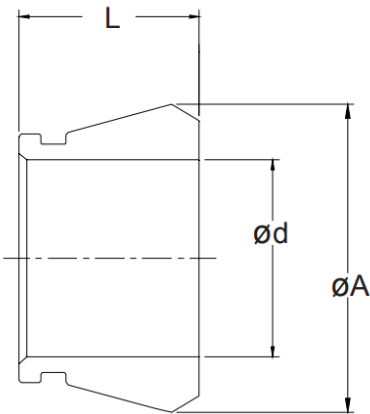

Collet Model	Collet Pad	Ød Max.	L	Range
SK65BZI/G/S16	S-16	1.625"	1.850"	± 0.020"
		41.3mm	47mm	± 0.5mm
SK65BZI/S20	S-20	2.000"	2.284"	± 0.020"
		50.8"	58mm	± 0.5mm
SK65BZI/S22	S-22	2.250"	2.323"	± 0.020"
		57.2mm	59mm	± 0.5mm
SK80BZI/S26	S-26	2.625"	1.850"	± 0.030"
		66mm	47mm	± .75mm
SK80BZI/S30	S-30	3.000"	1.850"	± 0.030"
		76.2mm	47mm	± .75mm

VULCANIZED RUBBER

MicroCentric Quick Change and "S" Pad Master Collets are hardened and precision ground segments held together by vulcanized rubber.

MicroCentric's vulcanizing technology produces a permanent bond between rubber and metal. However, if the rubber becomes damaged during normal use, the collet can be returned to MicroCentric and re-vulcanized. Contact one of our technical sales associates for information and cost.

6.0 COLLET CHUCK MODELS & SPECIFICATIONS

6.1 CB-NX COLLET CHUCKS

Chuck Model	CB42-NX	CB52-NX	CB65-NX	CB80-NX	CB100-NX
Collet Model	42BZI	52BZI	65BZI	80BZI	100BZI
Through Capacity	42mm	52mm	66mm	82.5mm	100mm
	1.625"	2.000"	2.625"	3.250"	3.937"
Accuracy (Max Radial Runout)	0.020mm	0.020mm	0.020mm	0.020mm	0.025mm
	.0008"	.0008"	.0008"	.0008"	.001"
Clamping Range	+/- 0.5mm	+/- 0.5mm	+/- 0.5mm	+/- 0.5mm	+/- 1mm
	+/- .020"	+/- .020"	+/- .020"	+/- .020"	+/- .040"
Max Clamping Force	80 kN	94 kN	105 kN	115 kN	150 kN
	17,985 lbs	21,132 lbs	23,605 lbs	25,853 lbs	33,721 lbs
Max Draw Tube Force	35 kN	40 kN	45 kN	50 kN	65 kN
	7,868 lbs	8,992 lbs	10,116 lbs	11,240 lbs	14,612 lbs
Max Speed	7,000 rpm	7,000 rpm	6,000 rpm	5,500 rpm	5,000 rpm

6.2 CB-ND COLLET CHUCKS

Chuck Model	CB42-ND	CB65-ND	CB100-ND	CB120-ND	CB140-ND	CB160-ND
Collet Model	42BZI	65BZI	100BZI	120BZI	140BZI	160BZI
Through Capacity	42mm	65mm	100mm	120mm	140mm	160mm
	1.625"	2.560"	3.937"	4.725"	5.512"	5.512"
Accuracy (Max Radial Runout)	0.020mm	0.020mm	0.025mm	0.05mm	0.05mm	0.05mm
	.0008"	.0008"	.001"	.002"	.002"	.002"
Clamping Range	+/- 0.5mm	+/- 0.5mm	+/- 1mm	+/- 1mm	+/- 1mm	+/- 1mm
	+/- .020"	+/- .020"	+/- .040"	+/- .040"	+/- .040"	+/- .040"
Max Clamping Force	80 kN	105 kN	150 kN	160 kN	170 kN	170 kN
	17,985 lbs	23,605 lbs	33,721 lbs	35,969 lbs	38,218 lbs	38,218 lbs
Max Draw Tube Force	35 kN	45 kN	65 kN	70 kN	75 kN	75 kN
	7,868 lbs	10,116 lbs	14,612 lbs	15,736 lbs	16,860 lbs	16,860 lbs
Max Speed	6,000 rpm	6,000 rpm	5,000 rpm	4,000 rpm	3,500 rpm	3,000 rpm

6.3 CB-NS COLLET CHUCKS

Chuck Model	CB42-NS	CB65-NS
Collet Model	42BZI	65BZI
Through Capacity	42mm	65mm
	1.625"	2.560"
Accuracy (Max Radial Runout)	0.020mm	0.020mm
	.0008"	.0008"
Clamping Range	+/- 0.5mm	+/- 0.5mm
	+/- .020"	+/- .020"
Max Clamping Force	80 kN	105 kN
	17,985 lbs	23,605 lbs
Max Draw Tube Force	35 kN	45 kN
	7,868 lbs	10,116 lbs
Max Speed	6,000 rpm	6,000 rpm

7.0 CHUCKING GUIDELINES

7.1 ACURACY AND RUNOUT

To obtain high accuracy workholding it is important to correctly match the collet diameter to the workpiece diameter being clamped. Each workpiece has a dimensional tolerance, and to achieve best chucking accuracy the collet should be sized to correspond to the largest diameter of the workpiece's range. Figure 7.1 illustrates the principle of single line contact by each collet segment. This condition will enable you to obtain minimum workpiece runout.

When a workpiece is clamped by a collet that has a diameter that is smaller than the workpiece diameter, the condition shown in Figure 7.2 will result. This will produce higher clamping force on the workpiece, however, accuracy will be sacrificed.

Even when close chucking accuracy is not required, it is always important to use a collet with the proper bore size for each workpiece or bar stock. Following this principle will maximize the overall performance of the collet chuck system.

In order to obtain close chucking accuracy, the collet's surfaces must be kept clean and free from chip buildup. On long running operations it is recommended that the collet be removed periodically for cleaning.

IMPORTANT

Apply a light film of grease to the tapered surface of the collet before installing it into the chuck to improve clamping force and runout.

IMPORTANT

To keep the clamping surface and collet seat free from chip buildup, the collet should be removed periodically from the chuck to be cleaned. Reapply a light film of grease to the tapered surface of the collet before reinstalling it into the chuck.

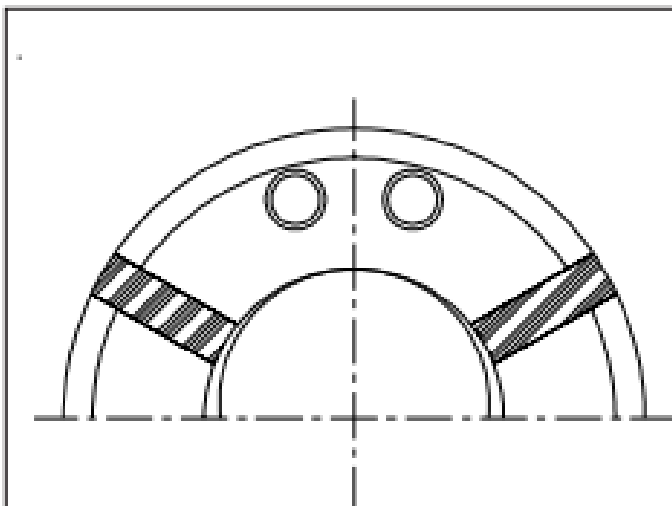

Figure 7.1

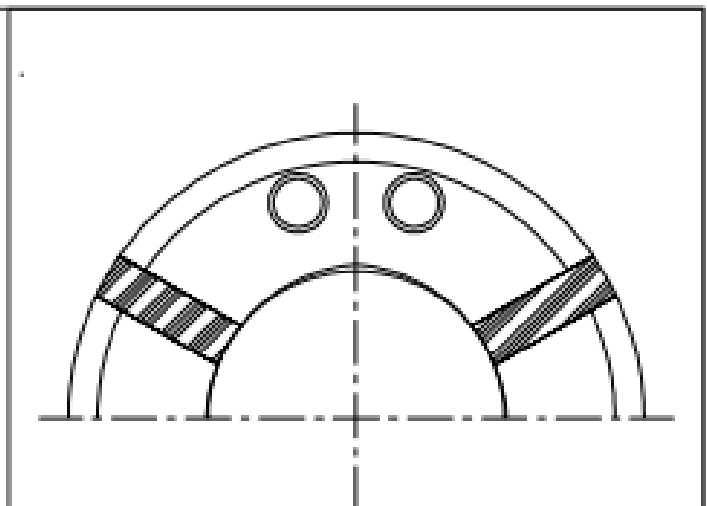

Figure 7.2

7.2 CLAMPING FORCE

Higher clamping force is generally required for roughing applications as compared to finishing operations. The clamping characteristics of a collet are enhanced by serrations, which will permitted higher rates of metal removal at the same draw tube force as compared to a smooth bore collet. The frictional force between the collet and workpiece or bar stock can also be increased by applying a carbide grit or diamond particle plating to the clamping surface of the collet. Sharp serrations that penetrate the surface of the workpiece provide the greatest clamping force to prevent workpiece slippage. Collets with widely spaced serrations also have enhanced clamping capability. The appropriate collet configuration for a given application is determined by a number of factors including cutting forces, spindle speed, and the material of the workpiece or bar stock. Recommendations for a specific applications can be obtained by calling MicroCentric's technical sales staff.

7.3 CLAMPING SHORT WORKPIECES

If the clamping length of a workpiece is .312" (8mm) or less, it is necessary to use a reduced nose collet. Figure 7.3 shows a reduced nose collet with a banking step clamping a short workpiece.

To accurately clamp short workpieces, the part must be located against a banking step in the collet (on dead length chucks) or against a part stop mounted inside the chuck body. In order to clamp short workpieces with minimum runout, the workpiece must have a square face to locate against.

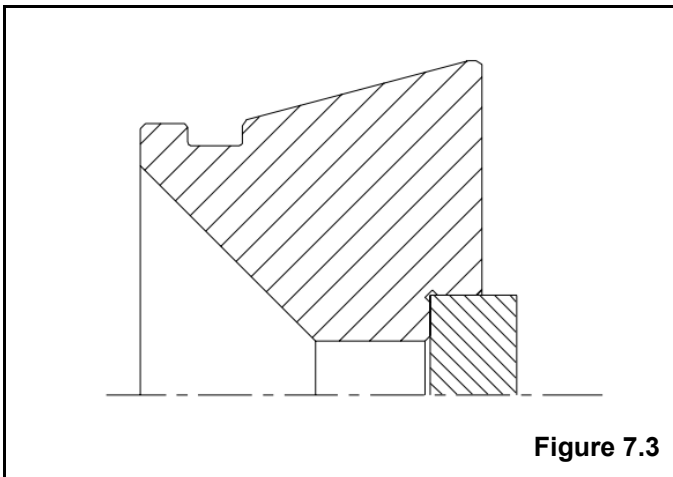

WARNING

Do not exceed the maximum recommended draw tube force for a specific collet chuck model.



CAUTION

Whenever the clamping length of a workpiece is .312" (8mm) or less, it is necessary to use a reduced nose collet.

7.4 END STOPPING A WORKPIECE

Part stops can be mounted inside CB-ND, CB-NS, and CB-NX series collet chucks to provide end location of the workpiece. Figure 7.4 illustrates a typical part stop configuration using a stop plate mounted inside the collet chuck body. Part stops, locators, and ejectors are available for specific workpiece applications. Contact MicroCentric's technical sales staff for information.

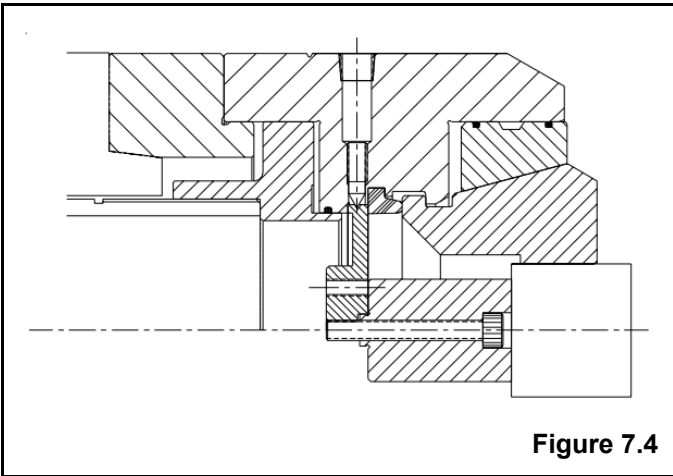

Figure 7.4

When using a dead length style collet chuck, a workpiece can also be end stopped on a banking face machined in the bore a collet, as shown in Figure 7.5 or on the front face of a collet as shown in Figure 7.6.

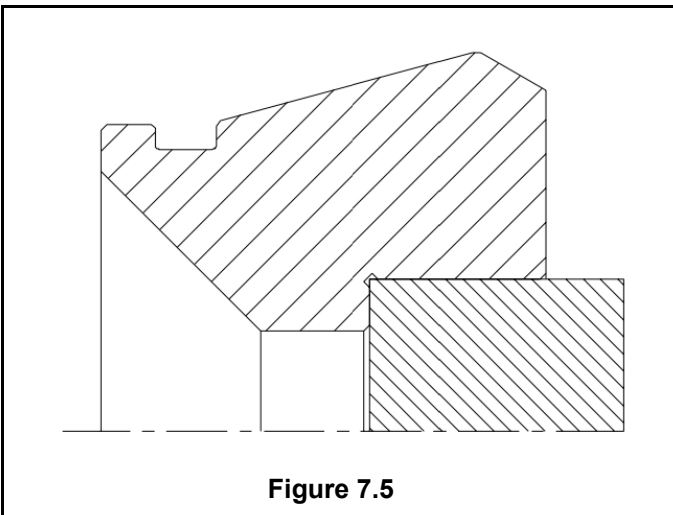

Figure 7.5

7.5 CENTRIFUGAL FORCE

The clamping force of a collet is affected by centrifugal force as spindle speed increases. Never exceed the maximum spindle speed recommended for a specific collet chuck model.

The loss of clamping force at high spindle speeds can be minimized by reducing the weight of a collet. Excess weight can be removed from a collet by drilling holes into the front face. For some high speed applications it may be necessary to dynamically balance the collet chuck. Consult MicroCentric's technical sales staff for further information.



WARNING

Do not exceed the maximum recommended spindle speed for a specific collet chuck model.



CAUTION

Collet chucks running at speeds above 4,000 rpm may need to be dynamically balanced.

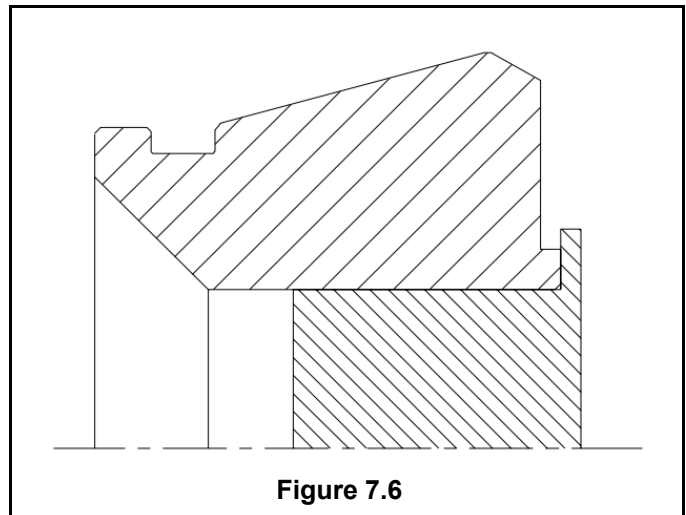
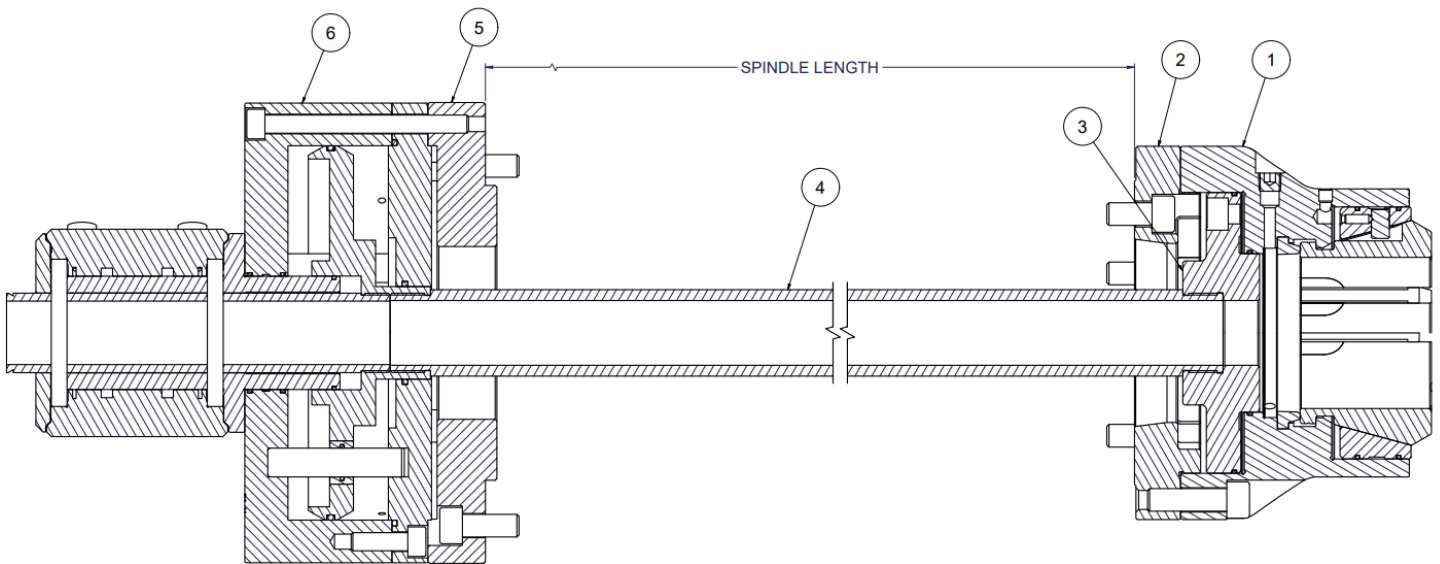

Figure 7.6

8.0 COLLET CHUCK SYSTEM ASSEMBLY



ITEM	QTY	TITLE
1	1	COLLET CHUCK ASSY
2	1	ADAPTER
3	1	DRAW TUBE CONNECTOR
4	1	DRAW TUBE
5	1	CYLINDER ADAPTER
6	1	CYLINDER ASSY (HYDRAULIC OR PNEUMATIC)

9.0 COLLET CHUCK INSTALLATION

MicroCentric collet chucks are supplied with a spindle mounting plate and a threaded draw tube connector to suit the machine configuration specified when the chuck was ordered. Refer to the chuck assembly drawings in Section 12.0 to familiarize yourself with the chuck's components before installation.

9.1 MOUNTING ADAPTER PLATE

1. Make certain that the spindle and the mounting plate are clean and free of nick or burrs that could prevent the proper seating of the adapter plate.
2. Mount the adapter plate to the machine spindle. Tighten the mounting bolts to the recommended torque value given in Section 4.0.
3. Use a dial indicator to measure the radial and face runout of the mounting surfaces of the adapter plate. Radial runout should not exceed $.0002''$ (0.005mm). Runout of the face should not exceed $.0002''$ (0.005mm). On flat spindle noses, the radial runout can be adjusted by loosening the mounting bolts and tapping the mounting plate with a plastic hammer. On tapered spindle noses no adjustment is possible. If the runout exceeds these values, remove the adapter from the spindle nose and ensure it is seated properly, and is clean and free from nicks and burrs. A skim cut can be taken on the pilot diameter and mounting face of the adapter once mounted to ensure both surfaces are running true.

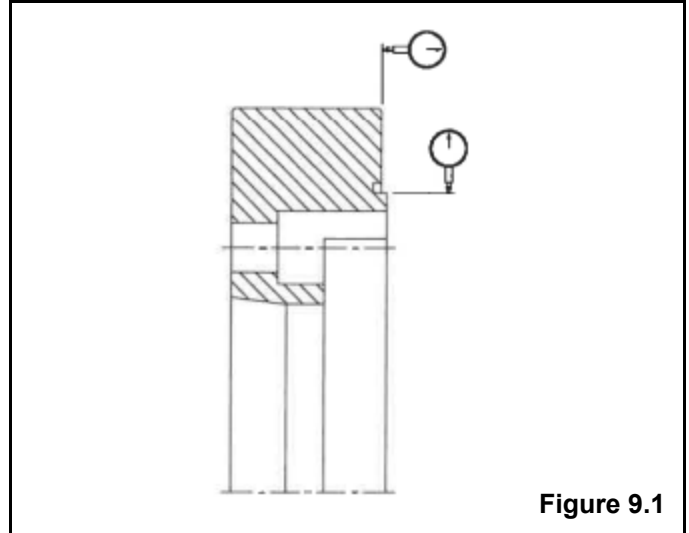

Figure 9.1

IMPORTANT

The runout of the mounting plate should not exceed $.0002''$ ($.005\text{mm}$) radially, and $.0002''$ ($.005\text{mm}$) laterally.

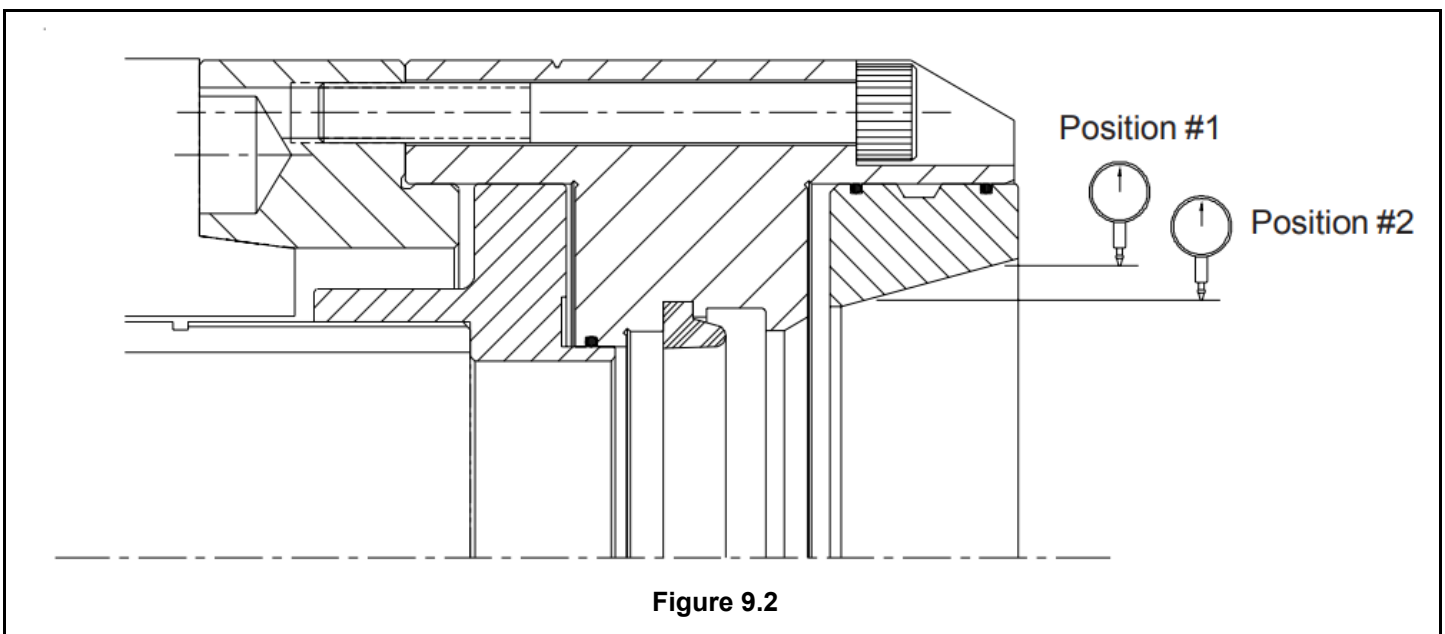

Figure 9.2

9.2 MOUNTING CHUCK ASSEMBLY

1. Set the draw tube force to the lowest pressure that is available for your machine. Actuate the draw tube to bring it to the forward position.
2. Make certain that the mounting surfaces of the chuck body and adapter plate are clean and free of nicks or burrs that could prevent the proper seating of the chuck body. Also make sure the (4) radial adjusting screws are not protruding into the locating diameter of the chuck body.
3. Take the entire chuck assembly and thread the draw tube connector onto the draw tube until the thread bottoms out. Back the chuck assembly off the draw tube thread 1/4 turn.
4. Actuate the draw tube to seat the chuck onto the adapter plate, and align the mounting bolts in the body with the mounting holes on the adapter plate.
5. Semi tighten all the mounting bolts, but do not fully tighten them at this point.
6. Indicate the ID runout of the collet taper as shown in position #1 in Figure 9.2. Make adjustments to the (4) radial adjusting screws so that the runout of the collet taper is within .0002" (0.005mm). Note: CB-NS collet chuck assemblies do not contain radial adjusting screws, and must be adjusted by loosening the mounting bolts and tapping the chuck assembly with a plastic hammer.
7. Before tightening the mounting bolts, measure the runout of the collet taper on position #2 in Figure 9.2. If the chuck body is properly seated on the adapter plate, the runout measured on position #2 should be the same as position #1. If the runout measured in position #2 exceeds the runout of position #1 by more than .0001" (0.0025mm), remove the chuck body from the adapter plate and repeat this mounting procedure.
8. After the runout of the collet taper has been adjusted, tighten the mounting bolts to the torque specifications given in Section 4. Also make sure to tighten all (4) radial adjusting screws.
9. Actuate the draw tube to verify that the chuck is functioning correctly by measuring the stroke of tapered sleeve as shown in Figure 9.3.

IMPORTANT

Verify that the chuck is functioning correctly by measuring the stroke of the collet sleeve.

IMPORTANT

The runout of the ID of the tapered collet seat should not exceed .0002" (0.005mm).

CHUCK MODEL	MIN. SLEEVE STROKE
CB42	.160"
	4.06mm
CB52	.160"
	4.06mm
CB65	.160"
	4.06mm
CB80	.160"
	4.06mm
CB100	.320"
	8.13mm
CB120	.320"
	8.13mm
CB140	.240"
	6.10mm
CB160	.320"
	8.13mm

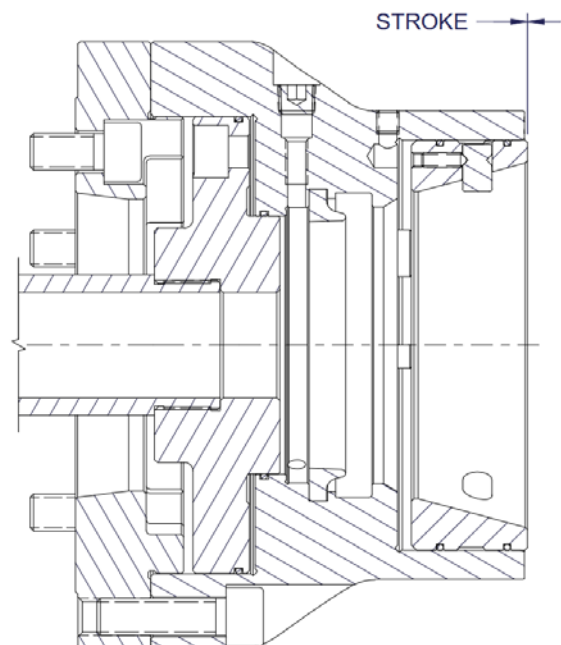

Figure 9.3

10.0 QUICK CHANGE AND “S” PAD MASTER COLLETS

MicroCentric quick change collets, and “S” Pad master collets are collapsed by a changing fixture for installation and removal from the collet chuck. Changing fixtures are available in manual and pneumatic models.

10.1 COLLET INSTALLATION

1. Insert the pins on the changing fixture into the holes on the face of the collet.
2. Actuate the changing fixture to collapse the collet. On manual changing fixtures turn the hand wheel clockwise until the rear of all collet segment are touching. On pneumatic changing fixtures depress and hold the trigger button.
3. With the collet fully collapsed, insert the collet into the tapered collet seat. Make certain that the key slot in one of the collet segments is aligned with the key in the tapered collet seat.
4. While pressing the rear of the collet firmly against the face seal inside the chuck body, release the collet by turning the hand wheel counterclockwise on the manual changing fixture. On pneumatic changing fixtures, release the trigger button.
5. Remove the changing fixture from the collet.
6. Actuate the chuck to make sure the collet is properly coupled in the chuck body. Also clamp a plug, bar end, or workpiece in the collet to verify the collet is clamping properly.

10.2 COLLET REMOVAL

1. Insert the pins on the changing fixture into the holes on the face of the collet.
2. Actuate the changing fixture to collapse the collet.
3. When the collet is fully collapsed pull the collet straight out from the chuck.
4. After the collet has been removed from the chuck, remove the collet from the changing fixture by releasing the changing fixture.

IMPORTANT

Verify the quick change collet or master collet is properly coupled into the chuck body by actuating the chuck before attempting to clamp a workpiece.

IMPORTANT

The collet chuck must be in the unclamped position when installing and removing collets. Dead length chucks are unclamped when the collet sleeve is fully retracted.

IMPORTANT

For master collets, remove the collet pads before installing or removing the master collet from the chuck.



CAUTION

Do not continue to turn the hand wheel on the manual changing fixtures after all collet segments are touching.



CAUTION

Do not exceed 100 psi inlet air pressure for pneumatic changing fixtures.

IMPORTANT

If the collet does not easily go into or come out of the coupling inside the collet chuck body, check to make sure the collet is fully collapsed. Check to make sure that chips are not preventing the collet from collapsing. Also make sure the collet chuck is in the unclamped position.

11.0 CHANGING FIXTURE ASSEMBLY & PARTS LIST

11.1 MANUAL COLLET CHANGING

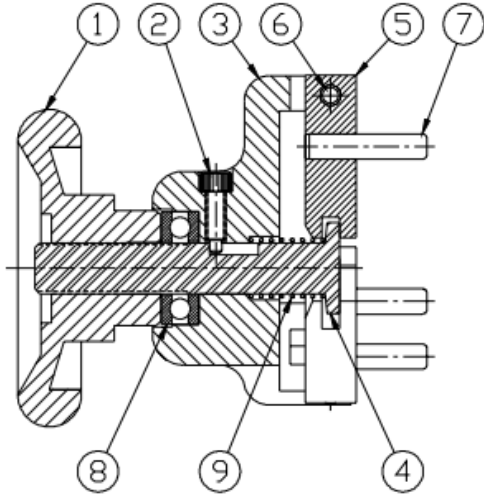

ITEM	QTY	DESCRIPTION
1	1	Hand Wheel
2	1	Retaining Screw
3	1	Housing
4	1	Rod Actuator
5	3	Jaw
6	3	Pivot Pin
7	3	Collet Pin
8	1	Bearing
9	1	Spring

11.2 PISTOL GRIP COLLET CHANGING

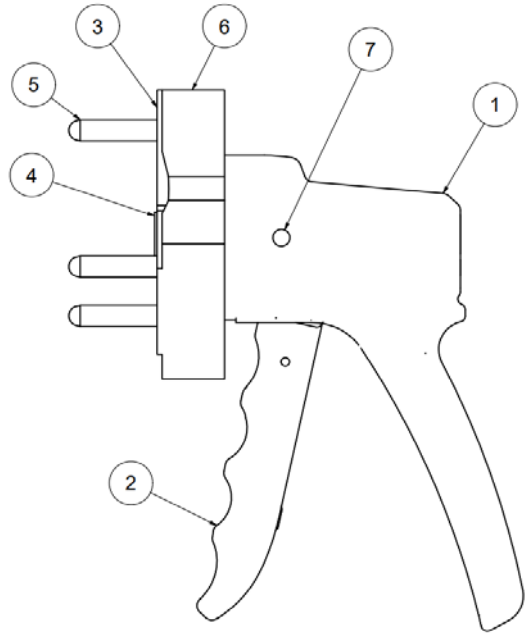

ITEM	QTY	DESCRIPTION
1	1	Housing
2	1	Trigger
3	3	Jaw
4	1	Bushing
5	6	Collet Pin
6	1	Front Plate
7	1	Retaining Pin

11.3 PNEUMATIC COLLET CHANGING

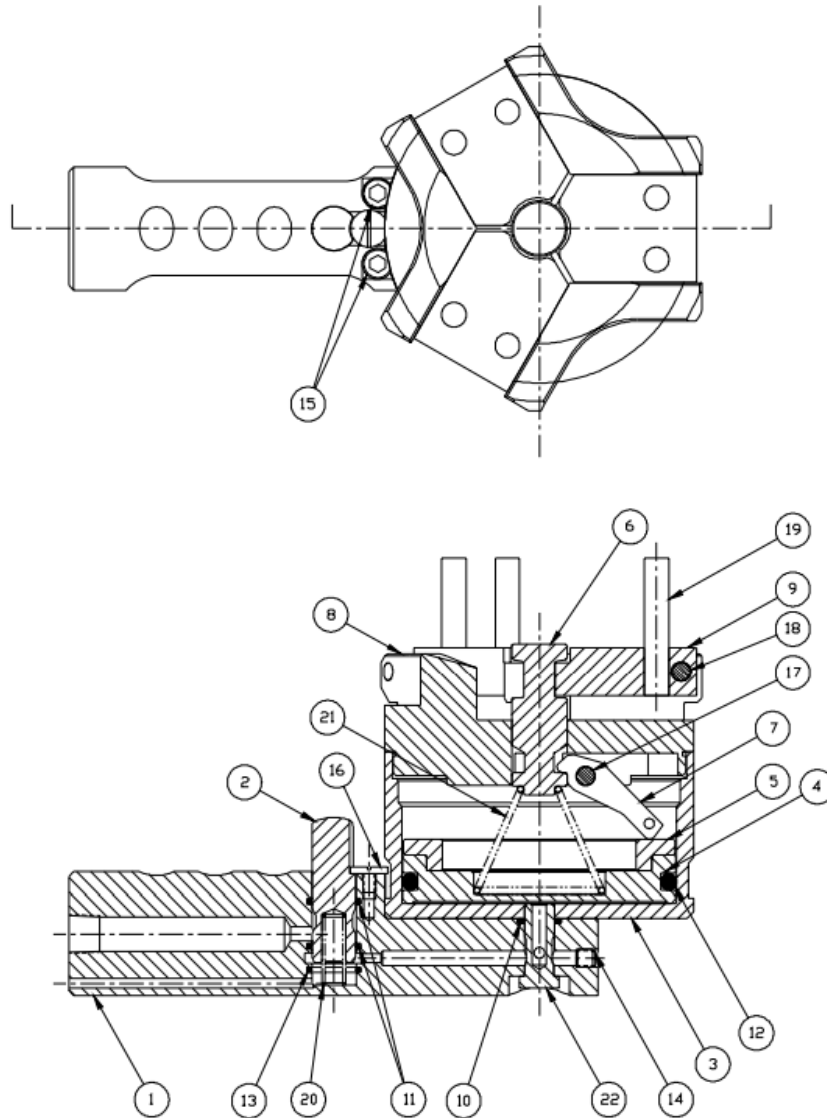

ITEM	QTY	DESCRIPTION
1	1	Handle
2	1	Trigger
3	1	Cylinder
4	1	Piston
5	3	Wear Plate
6	3	Actuator Rod
7	3	Lever*
8	1	Front Plate
9	1	Jaw
10	1	O-Ring
11	1	O-Ring

ITEM	QTY	DESCRIPTION
12	1	O-Ring
13	1	O-Ring
14	1	Set Screw
15	1	Socket Head Cap Screw
16	3	Retaining Screw
17	3	Lever Pivot Pin*
18	3	Jaw Pivot Pin*
19	1	Collet Pin**
20	1	Trigger Spring
21	1	Conical Spring
22	1	Hollow Bolt

*CP-100 Changing Fixture has six of each of these components.

12.0 ASSEMBLY DRAWING AND PARTS LIST

12.1 CB-NX COLLET CHUCK ASSEMBLY AND PARTS LIST

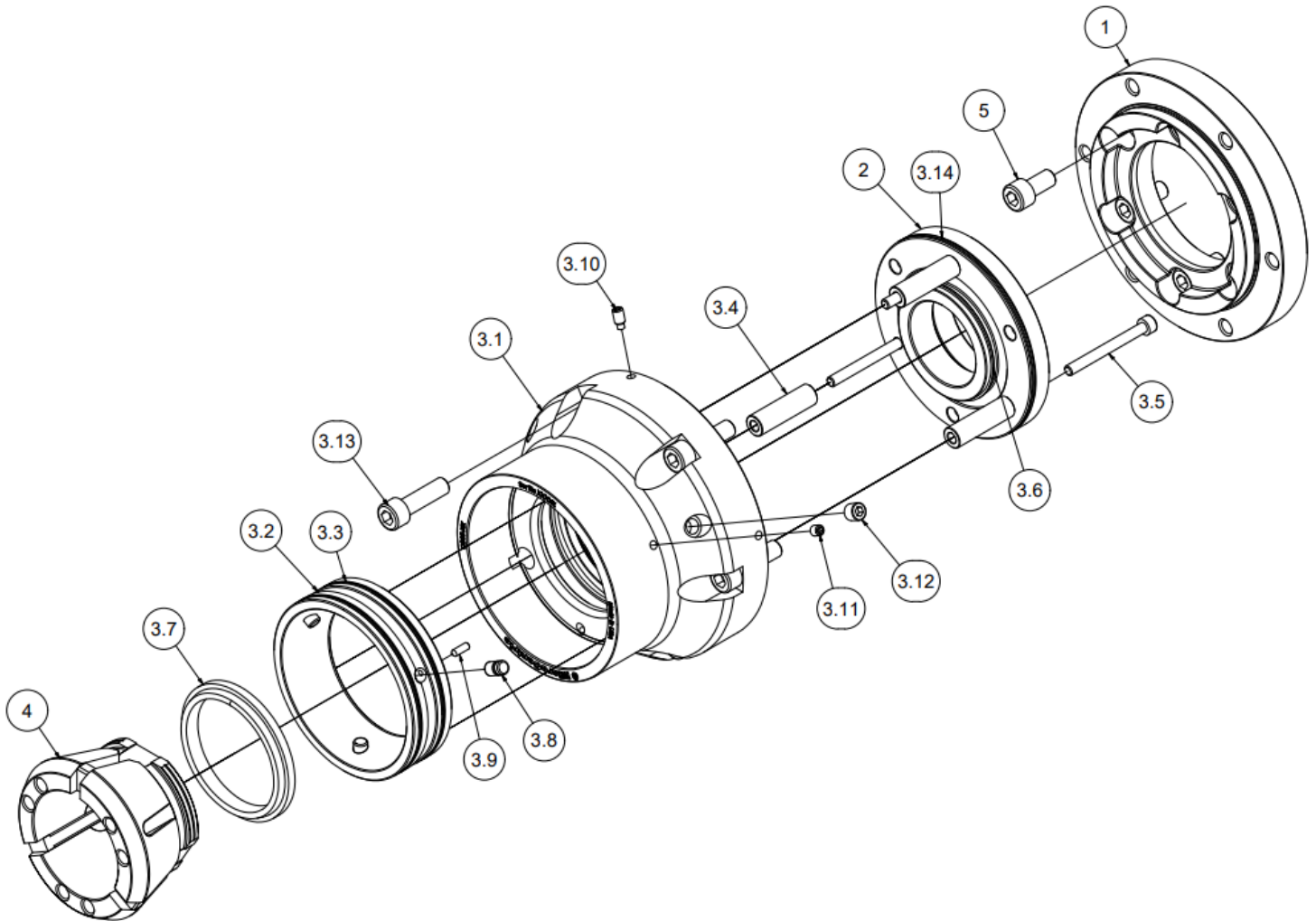

ITEM	QTY	DESCRIPTION
1	1	ADAPTER
2	1	DRAW TUBE CONNECTOR
3	1	FITTED BODY AND SLEEVE
3.1	1	BODY
3.2	1	COLLET SLEEVE
3.3	2	O-RING
3.4	3	BUSHING
3.5	3	SOCKET HEAD CAP SCREW
3.6	1	O-RING
3.7	1	FACE SEAL

ITEM	QTY	DESCRIPTION
3.8	3	LOCATING KEY
3.9	3	CONE POINT SET SCREW
3.10	4	DOG POINT SET SCREW
3.11	3	FLAT POINT SET SCREW
3.12	3	PRESSURE PLUG
3.13	6	SOCKET HEAD CAP SCREW
3.14	1	O-RING
4	1	COLLET
5	6	SOCKET HEAD CAP SCREW

12.2 CB-ND COLLET CHUCK ASSEMBLY AND PARTS LIST

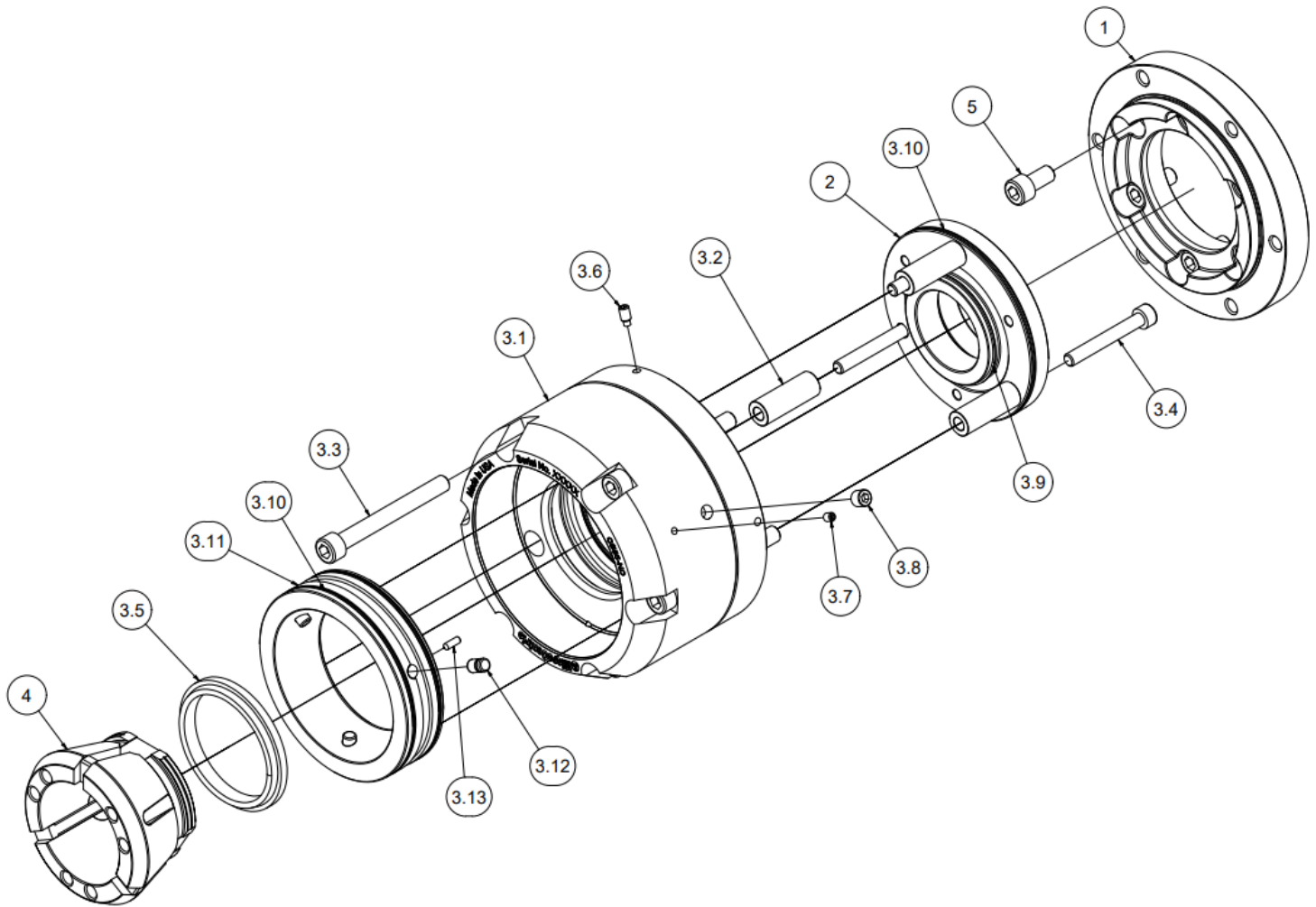

ITEM	QTY	DESCRIPTION
1	1	ADAPTER
2	1	DRAW TUBE CONNECTOR
3	1	FITTED BODY & SLEEVE
3.1	1	BODY
3.2	3	BUSHING
3.3	6	SOCKET HEAD CAP SCREW
3.4	3	SOCKET HEAD CAP SCREW
3.5	1	FACE SEAL
3.6	4	DOG POINT SET SCREW

ITEM	QTY	DESCRIPTION
3.7	3	FLAT POINT SET SCREW
3.8	3	PRESSURE PLUG
3.9	1	O-RING
3.10	3	O-RING
3.11	1	COLLET SLEEVE
3.12	3	LOCATING KEY
3.13	3	CONE POINT SET SCREW
4	1	COLLET
5	6	SOCKET HEAD CAP SCREW

12.3 CB-NS COLLET CHUCK ASSEMBLY AND PARTS LIST

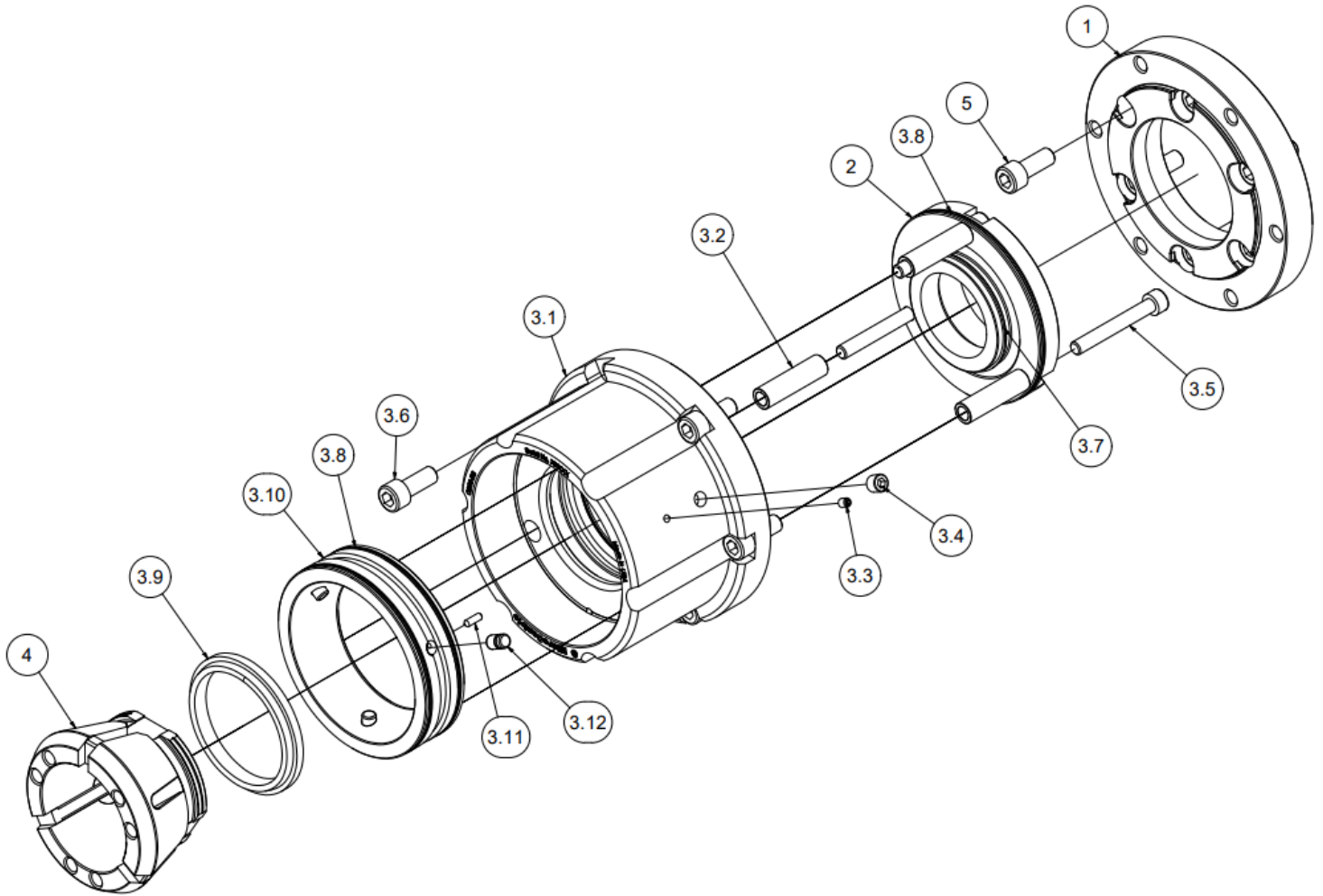

ITEM	QTY	DESCRIPTION
1	1	ADAPTER
2	1	DRAW TUBE CONNECTOR
3	1	FITTED BODY & SLEEVE
3.1	1	BODY
3.2	3	BUSHING
3.3	3	FLAT POINT SET SCREW
3.4	3	PRESSURE PLUG
3.5	3	SOCKET HEAD CAP SCREW
3.6	6	SOCKET HEAD CAP SCREW

ITEM	QTY	DESCRIPTION
3.7	1	O-RING
3.8	3	O-RING
3.9	1	FACE SEAL
3.10	1	COLLET SLEEVE
3.11	3	CONE POINT SET SCREW
3.12	3	LOCATING KEY
4	1	COLLET
5	6	SOCKET HEAD CAP SCREW

13.0 TROUBLE SHOOTING GUIDE

This trouble shooting guide is intended to help you identify some common causes of problems experienced operating MicroCentric collet chucks, or correctly clamping a bar or workpiece. For further assistance contact one of our technical sales associates.

PROBLEM	POSSIBLE CAUSE	SUGGESTED REMEDY
The tapered collet sleeve does not stroke fully.	The forward and retracted position of the draw tube was not specified correctly.	Refer to the spindle data sheet in Section 14. Remove the collet chuck from the machine spindle and measure the draw tube position.
	The threaded draw tube connector was not made correctly.	Compare the design of the draw tube connector with the spindle data sheet for the machine model the chuck is being mounted to.
	Chips and sludge mat have accumulated inside the chuck body preventing the collet sleeve and/or the draw tube connector from stroking fully.	Disassemble the chuck and clean all chips and sludge that has built up inside the chuck body.
Workpiece (bar) runs out excessively.	Tapered collet seat is running out, (mounting screws not tight).	Indicate ID of the collet seat and re-true chuck to within specifications given in Section 9.2. Make sure all mounting screws are tight.
	Chips, dirt, or other foreign material has accumulated between the collet and tapered collet seat.	Remove the collet and clean out all accumulated chips and sludge from inside the chuck, both from tapered seat and coupling area.
	The tapered collet seat in the chuck body is worn.	Replace the chuck body assembly or regrind the ID of the tapered collet seat.
	The clamping diameter and/or the OD taper of the collet have worn.	Replace or regrind the collet. Note only the clamping diameter of a collet can be reground.
Workpiece (bar) slips or pushes back during machining.	Collet is oversized for the bar or workpiece clamping diameter.	Use a collet with a clamping diameter that matches the OD of the bar or workpiece.
	Insufficient clamping force.	Increase the hydraulic pressure to the cylinder to increase the draw tube force to the chuck.
	Cutting force is too high.	Reduce cutting force.
	Coefficient of friction between collet and workpiece (bar) is insufficient.	Use a serrated collet. Use more aggressive serrations. Or apply a diamond particle plating or carbide grit to the clamping surface of the collet.
	Spindle speed is too high.	Reduce spindle speed.
Workpiece comes out of the collet, or collet uncouples from the chuck when clamping.	A workpiece whose overall length is shorter than .312" (8mm) is being clamped.	Use a reduced nose collet for clamping short workpieces. Refer to Section 7.3 on page 12 regarding the clamping of short workpieces.
	Too short a length of the workpiece is being clamped.	If using a standard nose collet, increase the length being clamped to .37" (10mm) minimum.
Pneumatic collet changing fixture does not actuate.	The air passage in the trigger button is clogged from using unfiltered air.	Remove the trigger button from the handle assembly and clear the clog in the air passage.

14.0 SPINDLE DATA SHEET

Company	
Chuck Model	
Date	
Ref. No.	

Contact us at **1-516-349-7220** if you have any questions about completing this data sheet.

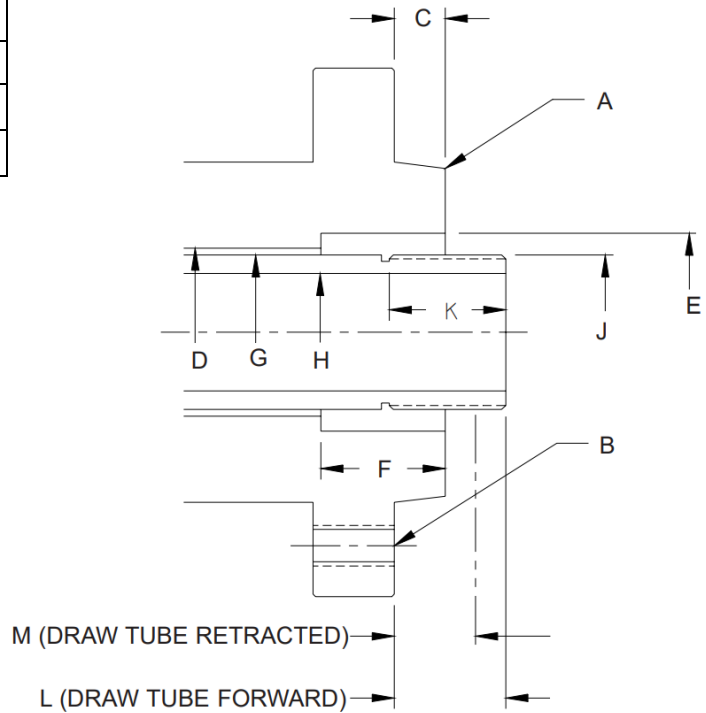

Machine Make		
Machine Model		
Machine Serial No.		
A* taper size		
B mounting thread		
C length of pilot		
D through hole diameter		
E ID counterbore or taper (if any)		
F depth of counterbore (if any)		
G OD of draw tube		
H ID of draw tube		
J thread data	thread diameter	
	thread pitch	
	right hand / left hand	
	OD thread / ID thread	
K length of thread		
L** forward position		
M retracted position		

* For machines with a straight spindle pilot a detail drawing of the spindle must be submitted

** Positive (+) indicates draw tube is in front of the spindle face (as shown)

Negative (-) indicates draw tube is behind the spindle face

Please email completed form to sales@microcentric.com



MicroCentric Corp • 25 So. Terminal Drive, Plainview, NY 11803 USA
Tel: 1-516-349-7220 • Fax: 1-516-349-9354 • e-mail: sales@microcentric.com

www.microcentric.com